



EDMUND LANGDON AND HIS WORLD

General Practitioner in Astronomie and Physicke

By Adrian and Sarah Hall and the
Battle and District Historical Society
Research Group

Battle, East Sussex, 2017

ISBN 978-1-903099-03-02

© Battle and District Historical Society

All rights reserved. No part of this publication may be reproduced, stored in a retrieval system, or transmitted, in any form by any means, electronic, mechanical, photocopying, recording or otherwise, without the prior permission of the Battle and District Historical Society.

Contents

Introduction and acknowledgements	
The start of a mystery	1
Who was Edmund Langdon?	2
How Edmund Langdon's work reached the Bodleian	8
The contents of Speculum Planetarum	9
The world of astrology and astronomy	21
Bibliography	27
Credits for illustrations	28

Introduction and Acknowledgements

A chance glance at a page in the 1865 Sussex Archaeological Collections introduced us in 2016 to Edmund Langdon. The then Editor, the Reverend Turner, sought information about Langdon's *Speculum Planetarum* produced in Battle in 1610. We decided to follow it up. Our enquiries led us to many places and institutions as we started to unfold the story of who Edmund Langdon was, why he produced his publication, and what kind of world did physicians and astrologers like him, inhabit in the seventeenth century?

This booklet tells the story of what we found out. It would not have been possible without the help, gratefully acknowledged, of the following:

BDHS Research Group: Keith Foord: research help and cover design

Bodleian Libraries, Oxford

Anne Bradley, School Archivist, Bristol Grammar School

East Sussex Records Office at the Keep

Gina and Kevin Doherty

Matt Edmonds, Millbrook Printers: for cover design

Julie Jessop: for proof reading and text layout

Dr Anne McLaughlin, Sub Librarian of the Parker Library, Corpus Christi College, Cambridge

Mr John Maddicott, College Historian, and Ms Penelope Baker, College Archivist, Exeter College, Oxford

Wellcome Foundation Library, London

Wiltshire History Centre, Devizes

THE START OF A MYSTERY

The story of this research began in 2016 when we noted the following message from the Editor, the Reverend Edward Turner, whilst browsing the 1865 Sussex Archaeological Collections:

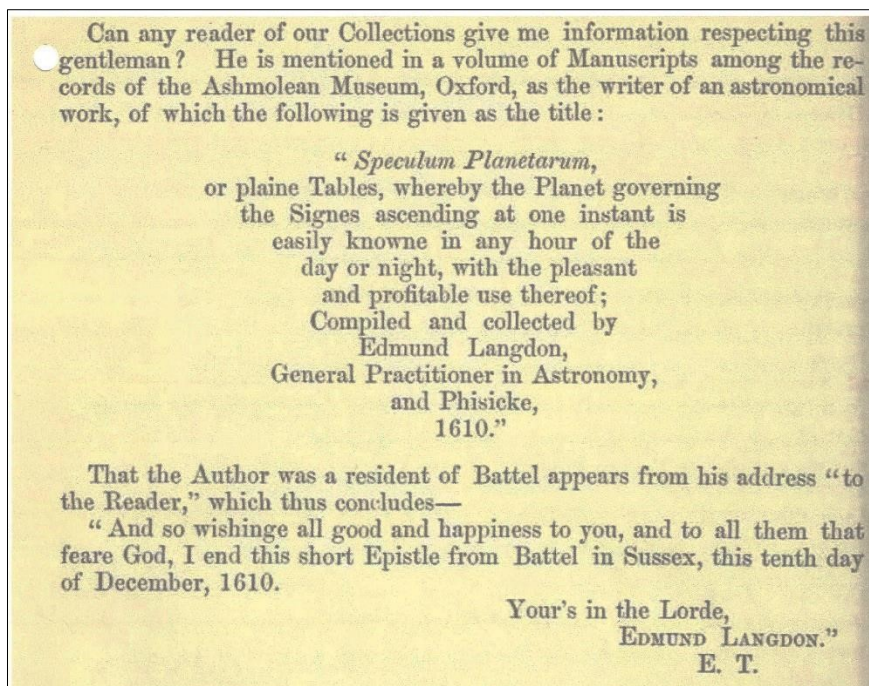

There appears to have been no reply to the Reverend Turner’s request, at least not through the letters pages of the Collection. This monograph attempts to provide an answer, 152 years later.

THE SEARCH BEGINS

So with the power of the internet we discovered that Langdon’s 1610 book *Speculum Planetarum* found its way somehow to the Ashmolean Collection of manuscripts, collected by Elias Ashmole and now housed at the Bodleian Library at the University of Oxford. We look at how this happened later on. The entry in William Henry Black’s 1845 catalogue of the Ashmolean Collection is reproduced here because some of the information became significant when tracing the history of what happened to Langdon’s book.

No. 433.

A thin folio volume, neatly ruled and written. The following title is written within a curious border of red lines, like to those round the pages of No. 437.

“*Speculum Planetarum*: or plaine Tables whereby the planet governeing and the signe ascendinge at one instant is easily known in any houre of the day or night, with the pleasant and profitable use thereof: compiled and collected by EDMUND LANGDON gent. Practitioner in astronomie and phisicke. 1610.”

On the two leaves following are a preface “To the reader” (dated “From Battel in Sussex this 10 of December 1610.”), and some introductory observations on the tables, which begin on the reverse of the fourth leaf, and occupy 144 pages.

“Now followeth ye pleasant and profitable use of this planetarie glasse.” p. 145—150.

“The table to know ye bodelic marke;” followed by two curious stories about its use. 151—2.

“Of the signes ascendinge.” 152—163.

On p. 165 is an astrological note (3 lines) written by Sir Rich. Napier.

2. “Clavis Spanheymem D. Ph. Duces Barm. Lond.

This title occurs abruptly in the 33 same hand as Napier, that they may

IV. A large thus—*The doctoure Pe and uniefrable. ff. 60*

Written by v to be a translation confusedly divided written, “Here en

V. “Liber cæli: conc

This title is tables begin) is names of ye fixed

We went to have a look at the document, not really knowing what to expect. Before we could be admitted to the Bodleian Libraries, we had to read out an oath, part of which promises not to kindle a fire – a reminder of the fire which consumed much of Thomas Ashmole’s collection in the eighteenth century but, fortunately, not including Langdon’s work. This monograph describes what we found and our subsequent research.

WHO WAS EDMUND LANGDON?

We begin by making some assumptions about Edmund Langdon’s age. It seems likely that he would have been in his thirties when in 1610 he finished *Speculum Planetarum* – the introduction refers to lengthy experience and experimentation – and it is unlikely that he lived to be much more than sixty, as was usual at that time. So we guess that Langdon’s dates were something like 1570/80-1630/40 (there is nothing in Battle records at ESRO in the Keep). If that is so, then it is possible – we can say no more – that “Mr Alexander” (referred to in Edmund Langdon’s book as an expert teacher in mathematics at Bristol – the Grammar School perhaps) may have been his teacher. We look into this in more detail later. Research at the Wellcome Collection has failed to identify any further information about Edmund Langdon as a GP. John H. Raach authored in

1962 the only “Directory of English Country Physicians 1603-43” which contains the name of Edmund Langdon, but the source for the entry is the Ashmole 433 manuscript which is the subject of this article.

We have done some work on where Edmund Langdon might have been born, if not in Battle. The Langdons originated in Exeter and their descendants spread out from there. A famous astrologer, Reverend Richard Napier, also came from Exeter and perhaps it is not a coincidence that he had a copy of *Speculum Planetarum* and passed it on to his nephew. In the course of looking for Langdon and variants of that name, we found a registration of baptism on 11 January 1573 for an Edmund Langdon at St Stephen’s Church, Winsham (50 miles from Bristol). Langdon is a common name but Edmund isn’t, and this may cut both ways as an *Edmond* (with an “o”) Langdon appears in the burial records of St Stephen’s for 31 May 1590. We hoped that a reply from Exeter College, Oxford would establish whether, like Napier, Langdon was a student at the College. Indeed, Napier was at the College as both student and Fellow for about ten years. However, the Langdon name does not appear in the College’s records.

The Battle and District Historical Society (BDHS) Research Group have tried to locate Edmund Langdon in local Battle records, but there are no leads. Thus we have no idea why, as a general practitioner in *astronomie and phisicke*, he was in Battle. Perhaps there was a good living to be had in the area and there were other medical doctors in the area around that time, e.g., Sedlescombe, Westfield and Burwash. On the other hand, other doctors of phisicke/astrologers whom he might have known were in London or north of London. As we shall see later, Langdon did not need to be in the countryside to have an unlit sky for his astronomical observations. One could speculate that he might have been in the Roman Catholic entourage of the Lady Magdalen of Battle. Some estimates suggest she had 120 in tow and at the end of the sixteenth century this large gathering gave Battle its nickname of “Little Rome”. She died in 1608 but he could have stayed on with the Montagus to finish his book. This idea, suggested by Keith Foord of the BDHS Research Group, has its attractions. There is no mention of Langdon in Questier’s comprehensive book about the Montagus and the recusants but the author is mainly concerned with priests.

It is at this point that we have two further leads, although not easy to reconcile as the same Edmund Langdon.

The first lead is that a devotional religious book with “Edmund Langdon” written into it has been found in the Parker Library of Corpus Christi College, Cambridge. He owned the book or at least used it.



Corpus Christi College, Cambridge

Published in 1504 and entitled *Speculum Disciplinae ad Novitios*, the book is about monastic and religious life, following the teachings of Cardinal (and Saint) Bonaventure, 1221-74. It is bound in with another book of similar theme and date, the *Dieta Salutis*. Corpus Christi’s records of alumni do not begin until well into the seventeenth century, so they do not know whether Langdon was a student at this college. Use of or ownership of this book by Edmund Langdon is consistent with him being part of Lady Magdalen’s “Little Rome” religious entourage. However, Dr Anne McLaughlin of the Parker Library at the College has been able to tell us that the College acquired this book in 1600, i.e., some ten years before Langdon surfaces in Battle. Perhaps Langdon parted with the book as he progressed on to astrology.

Additionally, Dr McLaughlin has drawn our attention to the inscription that accompanies Edmund Langdon’s signature. The handwriting is very similar to *Speculum Planetarum*, although we need to allow for the normative tendency of the Elizabethan scholar’s hand. Here is the relevant page:

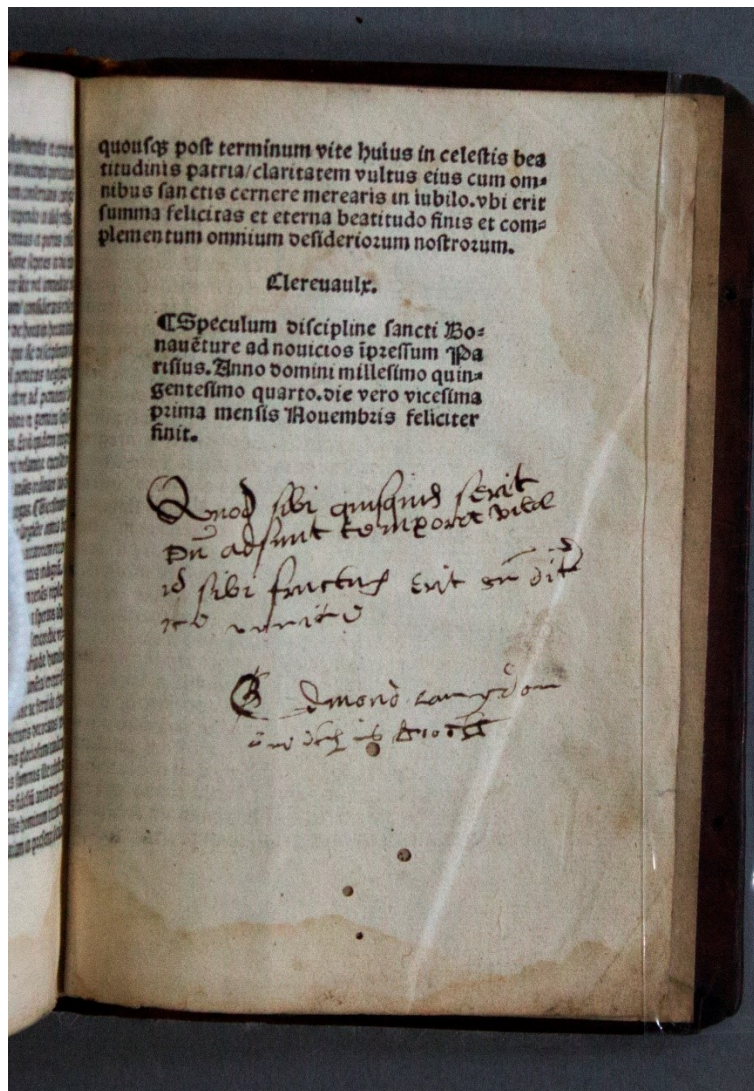

The two lines of the inscription above Edmund Langdon's signature are based on a widely-used religious aphorism which usually reads:

Quod sibi quisque serit praesentis tempore vitae¹
 Hoc sibi messis erit cum dicitur , ite, venite

But Langdon changes the wording (as shown in bold) – very unusual; indeed there is no other record of this being done:

Quod sibi quisquis serit **dum adsunt** tempore vitae
Id sibi **fructus** erit cum dicitur, ite venite

The inscription under Langdon's name is illegible.

¹ Whatever a person sows for themselves in this present life
 That will be their harvest, when it is said to them "it's time to go"

The main difference introduced by Langdon is the substitution of “fructus” for “messis” in the second line. Did Langdon have a reason for doing this or was it just serendipitous? We think we know why he used this word, at the risk of overinterpreting this hurriedly written entry. One of St Bonaventure’s trickiest jobs as Master General of the Franciscan Order was to resolve a dispute in Pisa between the Order and the local Franciscan nunnery of San Damiano, who expected pastoral care from the monks. This they were unwilling to provide and consequently in 1263 Pope Urban issued the instruction to the monks: *Spiritus Domini*. In this document he says that the nunnery is one of the fruits of the Franciscan Order’s efforts, using the word “fructus”, a Roman legal term for a product arising from natural resources or *from a legal obligation*. So by use of this word, perhaps the Pope is giving a veiled warning. Perhaps Langdon was reading *Spiritus Domini* while studying the teachings of St Bonaventure and had the word in mind when writing in his commentary? The book also includes the names of John Comin and Thomas Woodsole, but we have not been able to link Langdon to either of these individuals.

However, as we shall see later, Langdon does mention Dr Moulton, a Dominican friar whose 1531 book “The Myrroure or Glasse of Helth” was a classic for the rest of the century. It combined the received medical wisdom of the time, based on Hippocrates and Avicenna, with accounts of illness derived from astrology and religion. The combination of religion, medicine and astrology was not at all unusual at this time, so it is possible that Langdon could have been a priest or friar as well as an astrologer.

The second lead crops up in the Wiltshire Quarter Session Rolls of the Seventeenth Century edited by B. H. Cunnington (1932). These records tell of a set of actions by an Edmond Langdon (also known as Hopkins) in Malmesbury which are rather different at first sight from the Edmund Langdon we have come across in Battle. In 1617 Nicholas Reade claimed that this Edmond Langdon had sold his relative a piece of “paper written rounde about having Roman letters on the one side and figures on thither”, claiming that all the time he wore it he would not come to any harm, even from the Justices at his forthcoming trial! Langdon apparently claimed that “the same writinge was of such strong operation that yf yt weare hanged about a cocks neck, That then noe man shold have the power to kill the said Cock”. The examination of Langdon by the magistrates appears largely concerned with his previous whereabouts and his alias of Hopkins. Hopkins admits that he had been at Bedminster practising Phisicke and that he had “caste figuers” for finding lost horses. He had spent 20 years at Bristol under the name Hopkins to avoid prosecution in the Star

Chamber arising from a dispute between Lady Gresham and Boothe. He spent time at Bedminster, then went to Cardiff and after that Malmesbury. Langdon is indicted “for taking upon him by sorcery and inchantment to show where stoillen cattle might be founde” and referred to the Salisbury sessions for sorcery. However, there is nothing in the records to indicate what happened to him.

We have failed to find any evidence to back up the claim of the “Malmesbury” Edmund Langdon as to why he went under the name of Hopkins. He says that for about “twenty years paste he lay secretlie in Bristowe to avoid a Censure against him in the Starchamber in the cause betweene the Lady Gresham and Boothe at what tyme he named himselfe Hopkins”. There was indeed a famous case in the Star Chamber under Elizabeth I, in which Lady Gresham, widow of Sir Thomas Gresham, sued Roger Booth, a scrivener, and John Markham, a servant, for forging a 99-year lease for a rent charge. The litigation went on from 1579 to 1595, during which well over a dozen accomplices emerged, none of them with the name of Langdon or Hopkins. The case took a further turn when it was found that another deed had been forged: an assignment of an annuity which Sir Thomas Gresham had made on John Markham the younger, son of his servants John Markham and Anne Hurst. Langdon might have been an intimidated witness, but the records do not show evidence of that. It is more likely that the Langdon from Malmesbury knew that the justices in Wiltshire would be aware of the case, so his reason for having an alias would seem more plausible.

The description of the piece of paper containing Roman numerals and figures is not that far from a very simplified version of Edmund Langdon’s astronomical tables. Surely the Langdon of Malmesbury could not have been incognito as Hopkins in Bristol for the period 1597-1617 while also writing *Speculum Planetarum* from Battle in 1610? On the other hand, we do have a possible birth registration for Battle’s Edmund Langdon in Winsham in 1573. Winsham and Bristol (where we think Battle’s Langdon was educated) and Bedminster (where Edmund Langdon/Hopkins spent time) are geographically close. Could the same person be the student of St Bonaventure before 1600; then an acolyte of Lady Magdalen; then the astrologer and Doctor of Physicke in Battle in 1610; and also the conman of Malmesbury in 1617? Perhaps Langdon ran out of money a few years after Lady Magdalen died in 1608, returned to the West Country and had to earn a living in a rougher way? It is alternatively

possible that the astronomer Edmund Langdon, with his connections to Bristol, might have been the victim of what nowadays would be called identity theft.

HOW EDMUND LANGDON'S WORK REACHED THE BODLEIAN

This is an interesting story in itself. As we have seen, the Ashmole Collection entry for *Speculum Planetarum* in William Henry Black's catalogue says that some technical comments written into the book on a separate page at the back are by Sir Richard Napier (1607-1676): a doctor and astrologer born only three years before Langdon wrote *Speculum Planetarum*. Most scholars say that Sir Richard Napier inherited the library which was built up by his uncle the Reverend Richard Napier (1559-1634)² – a clergyman who operated in astrology and treated patients, mainly those with mental problems. The uncle collected books on the subject, including those by Simon Forman, a noted astrological physician and astrologer at the end of the Elizabethan Age. Forman advised him on difficult cases. The Casebook Project has digitised and indexed the extensive papers of Forman and The Reverend Napier (pictured), but Langdon's name does not appear.



² The Rev Richard Napier went to Exeter College, Oxford, where between 1580-90 he was first a student and then a Fellow. John Maddicott, the College Historian, says that Richard Napier was also known as Richard Sandye or Sandis, according to the College benefactor's book, which lists the gift of "Mr Richard Sandy, alias Napier, olim huius collegii scholar – £20". It is not within the scope of this study to investigate why he had an alias at this time of his life.

The Reverend Napier was an astrologer, certainly, so he and Langdon may have been part of the same group, but for most of his life Napier was Rector of Great Linford in Buckinghamshire and, as far as we know, they did not live within easy reach of each other. However, Napier was very well known: he had 40,000 patients throughout his career and his notes on them have survived! Langdon's book may have gone to the Reverend Richard Napier after Langdon's death because Napier lived 24 years after it was finished in 1610, and it would have been well known that he collected astrological books, having been left Forman's notes and library. As we see later, Sir Richard Napier, having inherited Langdon's book from his uncle the Reverend Richard Napier, appears to have used it because he wrote in it, and then in his turn Sir Richard left his collection of astrological works, including Langdon's, to his son Thomas. Thomas then sold the books to Elias Ashmole (1617-1692), who gave the books (most of which survived a fire) to Oxford University. The collection is now part of the Bodleian Library.

THE CONTENTS OF SPECULUM PLANETARUM

In the Bodleian Library, the book is presented in bound form. However, the binding appears to be of a much later origin, (probably nineteenth century) than the contents. So we cannot be sure whether Langdon's book was originally bound or loose-leaf.



As Langdon's introduction implies, the book was lent to friends for their personal use; we do not know whether he split the pages up when doing this. The book's 158 pages are all handwritten and it has been suggested that the phrasing strongly resembles dictation. If that is true we cannot even be sure that we are seeing Langdon's handwriting. The introduction and explanatory pages comprise six sides, the remainder of some 140 pages comprises tables of observations about the position of the planets each month in relation to the signs of the zodiac. The text advises medical treatments based on the planetary positions. There is no person to whom the book is dedicated, other than "The Reader".

In the first instance, we looked at the text to see what influences there might have been from, and on, Langdon. As we have seen, there were three lines of commentary in a different hand, placed on their own on the back of page 165. William Henry Black, the mid-Victorian editor for the Ashmole Collection, identified these as from **Sir Richard Napier**, possibly from prior knowledge of his handwriting. Napier seems to be making a note to himself about interpretation of Langdon's observations: "The Lo (*location*) of the seventh house is signifier of the Theife, the rather if he be peregrined in the 1.10, 7th or 4th or at least in the 2nd height/house, if there be too (*two*) Peregrined Planetts". Astrological positions, particularly those of Saturn and the Moon, could be used to determine the identity and location of a thief if something had been stolen. If Black is correct in ascribing this comment to Sir Richard Napier, then he may have been influenced by Langdon as he was only three when Langdon wrote *Speculum Planetarum*.

Reference is made by Langdon to a **Dr Moulton** – assumed to be the Dominican friar and astrologer Thomas Moulton, whose book "The Myrroure or Glasse of Helth" was a best-seller, running into nine editions during the period 1530-80. Paul Slack³ estimates that in 1604 some 166,000 volumes of do-it-yourself medical/astrological texts like this may have been in circulation in England. Moulton's book, like many others, advises medical treatments based on the position of the sun in the signs of the Zodiac. The book includes references to ancient and medieval medical authorities, such as Hippocrates and Avicenna, as well as discussion of humoral qualities such as heat, cold, dryness and wetness. Moulton's account of remedies for illness draws mainly on astrology and religion: his introduction says that the book "showeth howe the

³ In *Health, Medicine and Mortality in the Sixteenth Century*, ed Charles Webster, 1979.

Planetts reygne in every houre of the daye and nyght with the natures and expocisions of the xii signes devyded by the xii monthes of the yere, and sheweth the remedies for many divers infirmities and dyseases that hurteth the body of man”. Langdon’s book is organised on just this basis. Moulton’s book was clearly an influence on Langdon because Langdon mentions it, but it was typical of many others at the time.

There is also reference in Langdon’s book to a “**Mr Alexander** of Bristol, a mathematician” – we think this could be Mr Alexander Woodsonne, headmaster at Bristol Grammar School, 1584-1600. Perhaps he was the mathematics teacher at the School? The School’s records, checked for us by their archivist Anne Bradley, do not confirm or dispute this. There is a record of Mr Alexander Woodsonne being at St John’s College Oxford, graduating in 1573/4 and getting an MA in 1577. He might be the same person as the one-time headmaster at Bristol Grammar School. There was an Alexander Woodsonne – a “phesion” (physician) who died in Bristol in 1618 and, like Edmund Langdon, he might have combined maths and medicine. However, Mr Woodsonne of Bristol’s last will and testament does not indicate a clear link to Bristol Grammar School or to Langdon. Neither do the School’s records show a Langdon, nor is there a Langdon in the Bristol Archives database. So the records do not enable us to link definitively Woodsonne to Langdon. Nevertheless, the text in Langdon’s book does lead us to think that Langdon may have been a pupil of Woodsonne’s.

With the help of Anne Bradley we have been able to look at the inventory of the School’s library dating from the sixteenth century. Out of a couple of hundred books there are several on astronomy and astrology, and one in particular is important to this inquiry. We will come back to this later.

Langdon also refers to Hermes: **Hermes Trismegistus** (thrice-wise), a probably mythical author of the Hermetica, a corpus of ancient astrological/medical teachings — a memorial to him at Siena Cathedral is shown here.



Hermes and Thoth were the gods of magic and writing in Greece and Ancient Egypt, respectively. Thoth went on to become patron saint of astrology and alchemy. He and Hermes were “psychopomps”, guiding souls to the afterlife. “Albumazar” and others named in Langdon’s introduction were leading astrologers and mathematicians of the Muslim world; indeed Hermes is embedded in Islamic tradition. So we see that Langdon drew his thinking from ancient roots. As Gina Doherty of the BDHS Research Group has advised, “astrology formed part of diagnosis under the Galenic system of medicine, and looking at birth signs and the position of the stars would have formed a routine part of treatment and diagnosis, together with taking the pulse, examining urine and stools, taking the temperature, considering the complexion and the type of person being dealt with, e.g., phlegmatic, choleric, etc. The whole diagnosis would have led to a prescription which related to the whole lifestyle of the patient, including blood-letting in a particular place depending on the illness, recommendations on diet, exercise and sleep.” One might also add that astrology is thought to have originated in Babylonia, so there is a real fusion of cultures here.

Beyond these individuals, there is nothing in his book which leads us to Langdon’s influences or colleagues, but later we look into his contemporaries in the fields of astronomy and astrology who were working in the same or similar fields. Langdon should be seen as part of an interesting movement in sixteenth and seventeenth century England, where medical beliefs going back 1000 years were being combined with precise scientific observations of the heavens.

Here is the front page of the book.

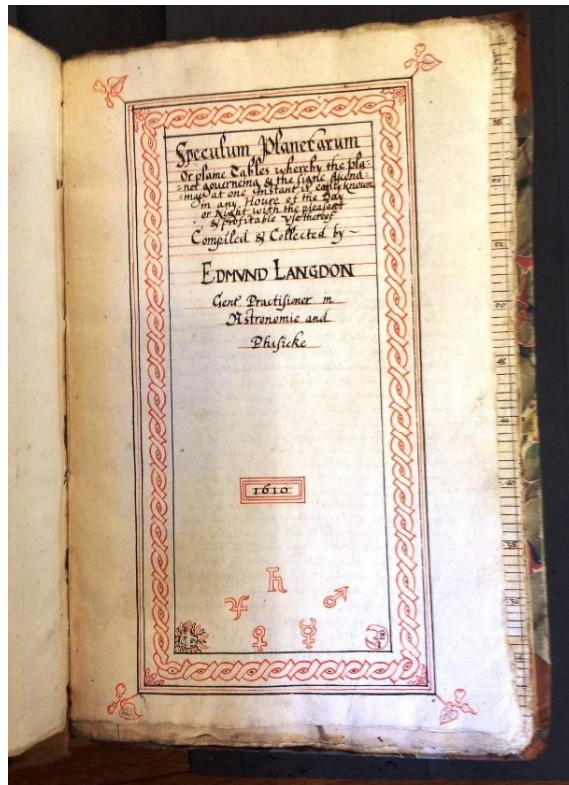

Then comes the introduction, although the “Elizabethan” hand is not easy to decipher.

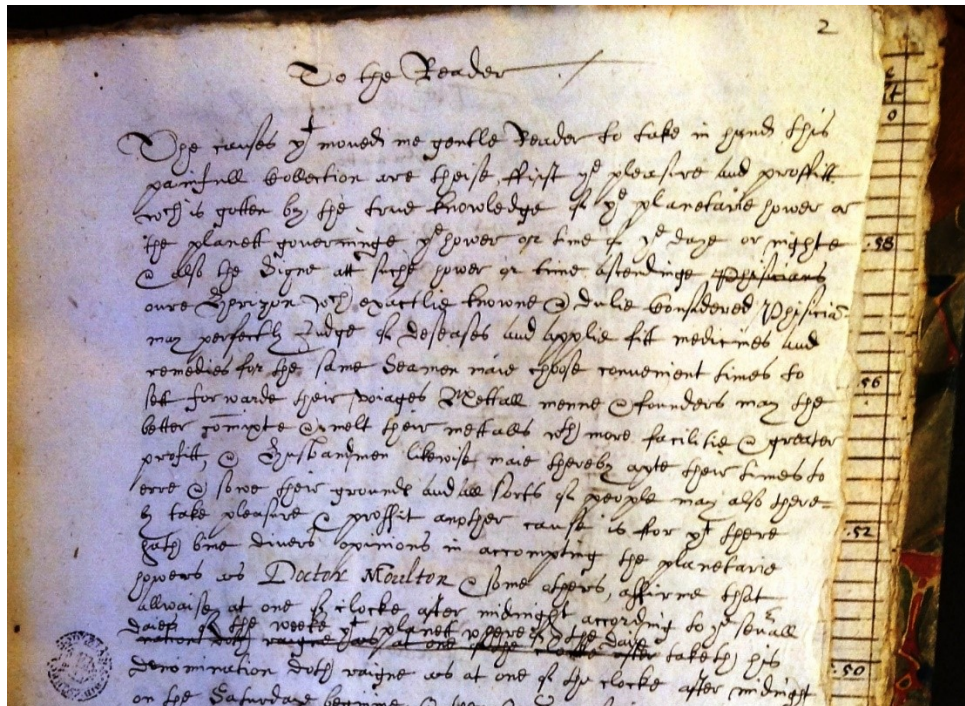

Fortunately, Gina and Kevin Doherty of the BDHS Research Group have “translated” for us. It reads as follows:

To the Reader

The causes that moved me gentle reader to take in hand this painfull [exertion?] are these, First the pleasure and profit which is gotten by the true knowledge of the planetary hower [and?] the planetts gouvourning the hower [or?] time of the daye or nighte & also the Signe att suche hower [or?] time ascending ~~Physicians~~ oure Horizon which exactlie knowne & duly considered Physicians may perfectly judge of deseases and applie fitt medicines and remedies for the same Seamen maie choose convenient times to sett forwarde their voiages Mettall menne & founders may the better [.....] & smelt their mettalls with more facilitie & greater profitt, & Husbandmen likewise maie thereby apte their times to eare & sowe their grounde and all sorts of people may also thereby take pleasure & proffit another cause is for that there hath [...] divers opinions in accompting the planetary howears as Doctor Moulton & some others affirme that allwaies at one of clocke after midnight according to the sevrall daies of the weeke that planetts [.. /] of the daie ~~nation doth raigne as at one of the clocke after~~ taketh his denomination doth raigne as at one of the clocke after midnight on the Saturday [.....] ☉ then ♀ ♃ & so in order which opinion is most erronious and false ffor ptholomaus Hermes ~~Mathematicions & skilfull in Astronomie~~ Tresmagistus Albumazar Alcabitus Nabed Mathematicions & skilfull in Astronomie & juditiall astrologie do accompt ab ortu solis from the ☉ risinge & so callinge the verie appearinge of the ☉ the first howre of the day [.] giveth the planetts of [.....] the same daie taketh his domination to the same first howre & so successivelie the residue of the planetts in order usque ad solis occasum unto the very going down of the ☉ & that they make the first howre of the night which opinion by great reason is true & because I [...] by practize & long experience founde the same so to be I compiled this worke for areadie helpe to my selfe not minding to publishe the same for the [.....] of the world but many of my Loving Friends so earnestlie persuaded me hereinto that I could not denie them. And lastlie although manie very Lernerd & [.....] hath framed and published perfect tables for the knowledge of the planeterie howers yet the same tables are not so [.....] to be [.....] of every delightfull [..... /] as these tables be to satisfie my freindes and to

pleasure and profitt the weale publique these pains I have taken which if I shall find acceptable it shall incourage me to adde further paines to this the [...] & [...] of this booke shall be shewed in order by divers documents & practized experiments with [...] examples to confirme the same & so wishing all goode & happines to thee & to all them that feare god I end this short epistle from battel in Sussex this 10 of December 1610

Yours in the Lord Edmunde Langdon

Astrological symbols

- ☉ - Sun
- ♀ - Venus
- ☿ - Mercury

On the face of it, Langdon has produced the book as a ready-reckoner for his medical treatments, trying to encapsulate observations about the procession of the planets through the sky which he has inferred from Hermes Trismegistus and confirmed by his own observations. One may speculate that the friends for whom he wrote did not have ready access to works such as that of Moulton and others which appear to cover the same territory.

Langdon produces 144 tables, one for each month and within that for each sign of the zodiac, showing the position of the planets, a sample of which is shown below.

The image shows a page from an old manuscript with a table titled "Hours from Mid-Night unto Passings". The table is organized into several columns, each representing a different planet or celestial body. The columns are labeled with abbreviations: "Sun", "Mars", "Jupiter", "Saturn", "Mercury", "Venus", and "Moon". Each column contains numerical data, likely representing the position or passage of the planet through the sky. The table is written in a cursive hand, and there are some red markings and lines drawn across the page, possibly indicating specific astronomical events or boundaries. The manuscript is aged, with yellowed pages and some wear at the edges.

We might speculate that perhaps Langdon thought he was adding to works by Moulton and others by providing his own observations, maybe from East Sussex; and a commentary possibly geared to the needs of the friends whom he mentions generically in the introduction.

We then looked at a passage on page 145 which we had hoped from its heading would describe how Langdon used his “planetarial glasse”- perhaps a telescope or similar instrument and, if so, a very recent invention at the time. It may be that the readings from this instrument reflected in Langdon’s detailed tables are the key to any originality in Langdon’s charts – generically this kind of work was very common in 1610. However, Langdon’s text says nothing about the planetarial glasse to help that interpretation; instead Langdon concentrates on explaining his astrological, as distinct from astronomical, practices. Again, we are indebted to Gina and Kevin Doherty of the BDHS Research Group for the “translation” which follows:

Now followeth the pleasant and profitable (?) [...] of this planetariel glase

*To him that inquireth for the sicke in the day and hower of ♄ (Saturn) you may answer
that he is sicke of a colde & had neede to have his livere (?) heated with some good thinge : his lippes be harshe & drie and the disease cometh of melancholie therefore there is winde in the stomache guts and bellie, the disease of the splene [.....] collicke ache itche and desir (?) luxurious. ♄ (Saturn) governeth the livoure gall and the fleshie parts of the stomache / he holdeth and restraineth all fluxes /⁴ he hath dominion in ♃⁵ ♌ (Capricorn) ♍ (Aquarius) and ♎ (Libra) for his exaltacion is in and under them⁶ /
he that falleth sicke in this hower of ♄ (Saturn) shall longe langwishe & hardlie escape /
the particular diseases to ♄ (Saturn) appropriate are the blacke jaundice bloodie flux palsie dropsie canckers crampe convulsion or contraction of synewes and generallie you may saie to the demandant for the sicke in this hower that his disease is colde and deadlie & beganne at the spleene & all parts of the bodie be greeved with windes but especiallie his stomache lungs and spleene
Wohe (?) to sickneth upon the Satterday if the 5th day be more greevous, he is*

⁴ / here and hereafter indicates where new clauses or sentences should, in our opinion, start

⁵ the symbol here is deleted but could either have been Virgo or Scorpio

⁶ assuming “dominion” is what modern astrologers call “rulership”, this would presumably make sense to them (if not to me)

*likelie to die the 14th day / if the 5 or 7 daie be easier he will live
 In the hower of ♄ (Saturn) take noe medicine nether cut not put on newe
 cloathes nether shave thie beard nor clipp thie heare nor enter into
 any shippe to journie by seaes for if you doe you shall surelie be
 tossed with waves if not drouned / hire noe servants / make noe fellow-
 shippe / strike no man with iron stone or arrowe nether goe into the feild
 with any man to fight / bleed not nor borrowe aney money neither sett out
 upon aney voyage excepte you maist return againe the same day for if
 thou dooe thou shalt finde many crosses⁷ for if thou travele by land you
 shall be imprisoned or in danger thereof or otherwise greatlie letted⁸ in the
 journey. And if thou goe by watter thou shalt be drowned or suffer
 many trublesom waves or contray winds which shall drive thee to places
 unknowne. And he that takes or borrows money in this hower shall have
 much trubles therewith & be in danger to be shaimd (?) by him of whome he hath it
 But in this hower you maiest goe a short journey of one diete⁹ which I un-
 derstand to be so short a journey as a man may returene home the same
 day and it is good to buy weapons to chase or followe thihe enemye or a
 theefe or fugitive, to write letteres (?) to ride horses to buy all manner of
 victualls to hier farmes to dich sowe or till the groundes and to digge
 welles. If demande be made for thefte or for a fugitive in the first quar-
 ter of this hower of ♄ (Saturn) siae the theefe or theft is gone South / in the second
 quarter East, in the 3 quarter West in the 4th northe & saie the theefe
 is a blacke haired man highe or [.....] shoulderd / his knees going something
 neare togetheurs & duth shaille¹⁰ or smite one foote against another as he goeth
 and hath a drie rough haire [.....] & greate vaines and is beetle browed
 and hath little eyes & but a thine beard and looks allwaies downward / in the first
 quarter of the hower if demand be made he is very young / in the
 2 quarter of middle age / in the 3 or 4 he is an ould man and by trade or
 profession he is a husbandman dicher fyer (?) of japes or a great purchaser*

Much of this is similar to the work which **Simon Forman** (1552-1611) was doing although, perhaps because he was a controversial figure, he is not acknowledged in Langdon's book. We cannot find a link between Langdon and Forman except that we found "another" Edmund Langdon in south London not far from one of Forman's bases. Like many others less well known, Forman combined astrology, magic and medicine, specialising in advising clients about life choices, much as it appears Langdon was doing, from the positions of the

⁷ crosses = troubles, vexations, annoyances (OED)

⁸ letted = hindered, impeded (OED)

⁹ diete = a day's journey (OED) – although Langdon supplies his own definition here

¹⁰ shaille = walk or move in a shuffling manner (OED)

planets in the zodiac. Indeed one of Forman's books "De Horis Planetaris" is very similar in that it was designed to predict events.

Langdon probably stays silent about Forman (pictured p.20) because the latter was controversial at the time. He was notorious for having sexual relations with many of his female patients, as we know from his casebooks discovered in 1974 by A. L. Rowse. He was frequently on the run for avoiding registration with The Royal College of Physicians, who pursued him endlessly; and even after his death he was caught up in the Thomas Overbury scandal. Frances Howard, Countess of Essex and Robert Carr, Earl of Somerset were accused of murdering Thomas Overbury to facilitate their marriage. It was alleged that one of Frances' ladies, Anne Turner, had consulted Forman on her behalf about love potions. The prosecution argued that Forman might also have been the source of the arsenic said to have killed Overbury. Howard and Carr were eventually pardoned; Anne Turner was hanged. At his death in 1611, Forman left his papers to The Reverend Richard Napier (1559-1634), whom we have already met: one of his protégées and a cleric in Buckinghamshire who provided Forman with his chemical supplies. As we have seen, Napier features in the Langdon story as well, and as the recipient of his papers; but we cannot prove Forman and Langdon knew each other as there is no mention of Langdon in any of Forman's extensive, carefully analysed and indexed papers.

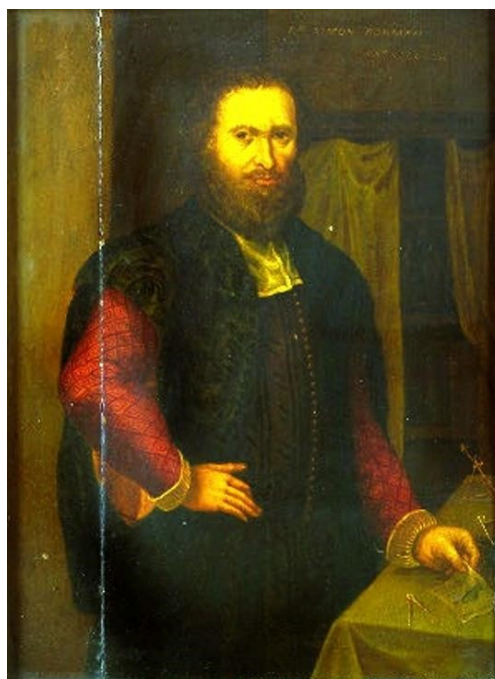

Langdon provides a ready-reckoner, pictured on page 22 as it appears in both the original and in Keith Foord/Gina & Kevin Doherty's modern rendition, respectively. The table's purpose is to identify which planets and signs of the zodiac, when in conjunction, govern the treatment of particular parts of the body. Ready-reckoners and almanacs like this – for example John Maplet's *The Diall of Destiny* (London: Thomas Marshe, 1581) – were common in the Elizabethan/Jacobean era; even Burghley and Wolsey consulted them. In the photograph, signs of the zodiac are on the left and across the top are the signs of the planets, moon and sun. The parts of the body most suitable for treatment at the conjunction of sign and planet are shown in the boxes. The traditional astrological concept lying behind this approach is that the sun, moon and planets are more powerful and effective in some signs, and may be weaker in others. The paradigm for this is categorised as Dignity and Detriment, Exaltation and Fall: these terms applying to assessment of different types of strength and weakness. Langdon's advice in the book does not seem new at all; Simon Forman's "Astrologically Judgements of Phisick and other questions" has very similar advice, as do Napier's notes. Langdon writes like Forman and Napier, switching into abbreviations of heavenly positions and signs in the middle of a prose sentence. However, neither Forman nor Napier published an almanac of the kind produced by Langdon and that is the difference. They undoubtedly would have had such a guide for reference but no reason to publish it because of the enormous number of their patients. Langdon's friends, for whom he wrote the almanac, may have found it useful to pass this around between themselves for a bit of DIY treatment or similar.

However, we have to be careful not to attribute too much innovation to Langdon, as shown by one of the books in the Bristol Grammar School Library. This is the *Almanach Nova* published in 1506 by Johannes Stoffler, a German mathematician and astrologer (1452-1531) based at the University of Tübingen. A century later, Langdon's charts, which plot the position of the planets against the signs of the zodiac, are very similar to Stoffler's.

The table to knowe y^e bodelie Marke

	♄	♃	♂	♁	♆	♅	♁
♄	Breast	Belly	Head	Thigh	Feet	Thigh Legs	Knees
♃	Belly	Back	Neck	Knees	Head	Feet	Thigh
♂	Belly	Privates	Breast Stomach	Thigh	Neck	Head	Thigh Legs
♁	Privates	Thigh	Breast	Feet	Arms Shoulders	Throat Eyes	Head
♁	Feet	Knees	Belly	Neck	Belly	Heart	Shoulder
♆	Knees	Head Eyes	Privates	Shoulder	Head	Belly	Heart
♅	Buttocks	Feet	Head Arms Thigh	Heart	Privates	Back	Belly
♅	Privates	Thigh Knee	Belly	Head	Heart	Shoulders Throat	Neck
♆	Feet	Thigh Head	Hands Feet	Belly	Arms Thigh	Heart Privates	Back
♆	Head Feet	Knees Eyes	Thigh Shoulder	Back	Heart Thigh	Privates	Thigh
♆	Head Neck	Shoulders Breast Feet	Heart Hips	Privates	Knees Shanks	Heart Thigh	Privates
♆	Shoulder Arm Neck	Head Heart	Arse Belly	Thigh Shank	Neck Back	Thigh Privates	Throat

The table to knowe ye bodelie Marke

	♄	♃	♂	♁	♆	♅	♁
♄	Breast	Belly	Head	Thigh	Feet	Thigh Legs	Knees
♃	Belly	Back	Neck	Knees	Head	Feet	Thigh
♂	Belly	Privates	Breast Stomach	Thigh	Neck	Head	Thigh Legs
♁	Privates	Thigh	Breast	Feet	Arms Shoulders	Throat Eyes	Head
♁	Feet	Knees	Belly	Neck	Belly	Heart	Shoulder
♆	Knees	Head Eyes	Privates	Shoulder	Head	Belly	Heart
♅	Buttocks	Feet	Head Arms Thigh	Heart	Privates	Back	Belly
♅	Privates	Thigh Knee	Belly	Head	Heart	Shoulders Throat	Neck
♆	Feet	Thigh Head	Hands Feet	Belly	Arms Thigh	Heart Privates	Back
♆	Head Feet	Knees Eyes	Thigh Shoulder	Back	Heart Thigh	Privates	Thigh
♆	Head Neck	Shoulders Breast Feet	Heart Hips	Privates	Knees Shanks	Heart Thigh	Privates
♆	Shoulder Arm Neck	Head Heart	Arse Belly	Thigh Shank	Neck Back	Thigh Privates	Throat

THE WORLD OF ASTROLOGY AND ASTRONOMY: LANGDON'S CONTEMPORARIES

We have surveyed other contemporary astronomers and astrologers to see if any of them had a link with Langdon. **John Dee** (1527-1608/9), a courtier of Elizabeth I, combined his study of mathematics with those of Euclid and Hermes Trismegistus, and in particular the summoning of angels through a medium or crystal gazer (“scryer”) and divination. Dee was a man of wide interests, a close friend of the cartographer Gerardus Mercator. He amassed a huge personal library and invented the term “British Empire”. In 1555 he got into trouble for casting horoscopes of Queen Mary and Princess Elizabeth.

While at court, he performed experiments in combustion to entertain Elizabeth I, as shown below in Henry Gillard Glindoni's nineteenth century depiction. Dee advised Elizabeth's courtiers about cryptography. In the 1580s Dee travelled through eastern Europe as an astrologer with **Edward Kelley**, a “scryer” or crystal gazer. Kelley persuaded Dee that the angel Uriel had told him he must sleep with Dee's much younger wife, to which Dee (unhappily) agreed! Kelley also invented Enochian- an occult or angelic language which of course only he could understand. There is no evidence from Dee's papers that he and Langdon knew each other, although their work bore many similarities and we may assume Langdon at least knew of Dee.



As we have seen, Moulton's work, whose influence Langdon acknowledges, was one of many who tried to advise on the interpretation of heavenly bodies and their positions. For example **Leonard Dygges** from Barham in Kent produced his book "The General Prognostication" (published in 1553 and expanded in 1555) which contained astronomical charts, a perpetual calendar, and "rules and precepts" for determining the motions of the stars, sun, planets and Moon. This work was widely sold. Also, in what follows, we need to bear in mind the implications of Langdon describing himself as a Doctor of Physicke. As Johnson points out, at this time the physician had to make astronomical observations and astrological calculations: astronomy was an important but subsidiary part of the curriculum for the degree of Doctor of Medicine.

Leaving that aside for the moment, we have given some thought to Langdon's reference to a "planetarial glasse" and its implications, always bearing in mind that we cannot find this phrase anywhere in the literature. However, the term "perspective glasse" is often used. Langdon does not describe how and what astronomical instrument he used; only the astrological interpretations provided by instrument. The instrument he used might have been some kind of telescope (not a term known at this time) but, as described below, there are other instruments he might have used.

Following at least a year's observations Langdon wrote *Speculum Planetarum* in 1610. In order to obtain the observations made, he would have had three options:

- (a) Langdon might have used a primitive precursor of the sextant called a "backtsaff" (pictured below), which was invented around 1590 and used for fixing the positions of the stars.

There were variants with a glass eye-piece. It should be borne in mind that Langdon did not have to observe the details of the planets like Harriot or Galileo – just identify them in the right part of the sky.

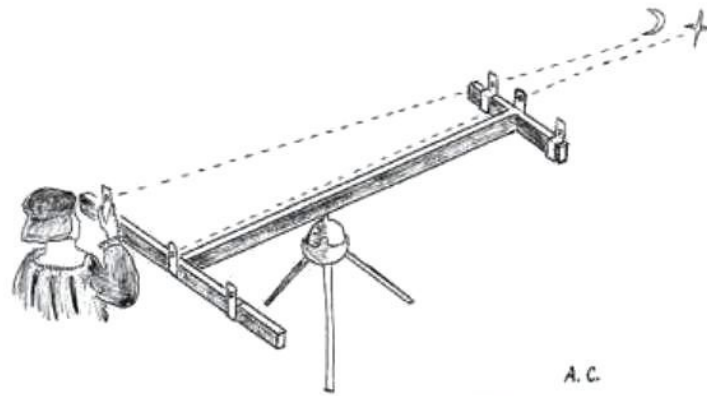

Thomas Harriot's Cross Staff, or Astronomical Radius of 12 feet. The Radius was a common instrument in the 16th and early 17th centuries, and was used to measure celestial angles. Using the fixed sight through the long axis, guided by an assistant, the astronomer would move the sliding brass sights towards the Moon or a star. The graduations on the rods then enabled the angle – in the present example, between the Moon and a star – to be calculated by means of the Rule of Tangents. *Drawing by Dr Allan Chapman.*

(b) He might have been using a primitive “telescope” (a term invented long after this period) of the kind that Leonard and then his son **Thomas Dygges**, also not far away at Barham in Kent, used in the Elizabethan era. This “perspective glasse”, described in Thomas Dygges’ *Pantometria* (1571), was assessed for the Government by navigational expert William Bourne – some scholars think that Burghley inferred from Bourne’s report that the device could complicate tactics for dealing with the Armada, particularly if news of the instrument’s existence reached the Spanish. Thus some historians believe that Lord Burghley restricted the circulation of accounts of this instrument. It appears to have consisted of a convex lens and a concave mirror. Some scholars, for example Colin Ronan in 1991, think this instrument may have been not only a refracting telescope but also the earliest known reflecting telescope (i.e., the image on a mirror is viewed from a side eyepiece), an invention usually credited to Newton. Others conjecture that the glass materials in Elizabethan England could not have been made fine enough for this instrument to work. Nevertheless, they then have to explain how Thomas Dygges managed to produce this astronomical map:

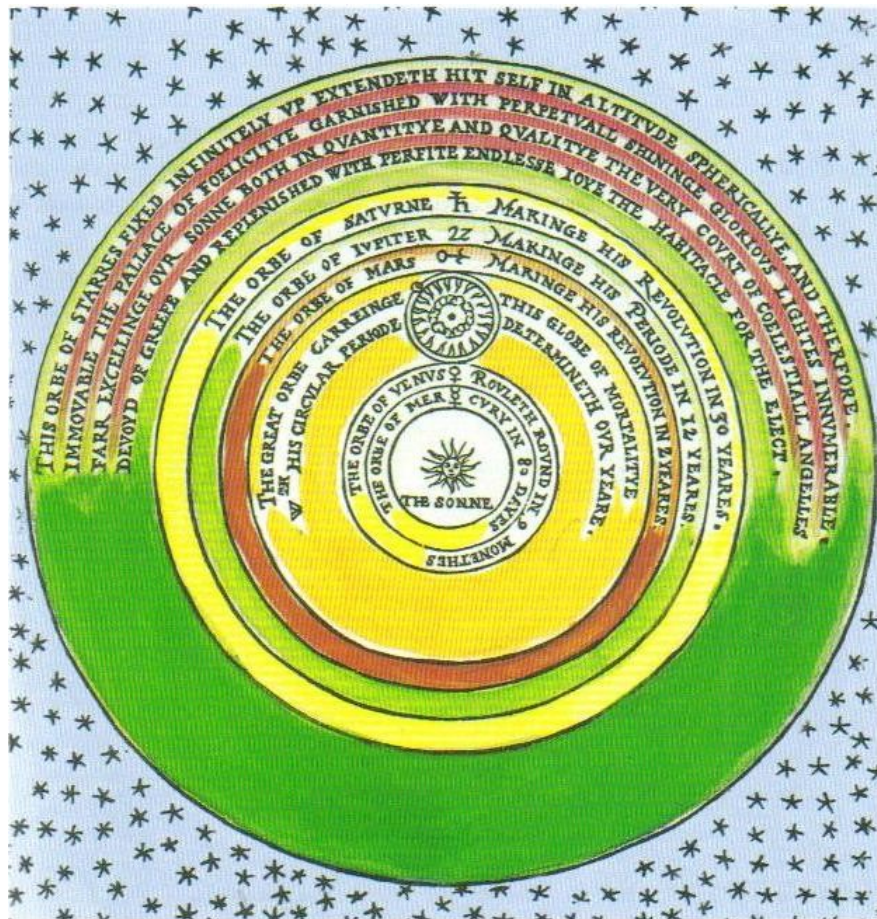

Thomas Dygges was of some stature in the astronomical world, having observed a supernova in 1572 for which he received credit in one of Tycho Brahe's publications.

(c) If Langdon had been caught up in the interest in telescopes contemporary with the writing of his book, he might have used a "Dutch trunke". In 1608 **Hans Lippershey**¹¹ failed to get a patent from the Dutch Estates General for his simple refracting telescope (in which light and image are concentrated on an objective lens) and, unfortunately for him, the publicity set off many imitations in the year immediately following. On 27 July 1609¹² **Thomas Harriot** used one of these telescopes (with a magnification of x 20) to observe the Moon from Syon Park: he had no need to go further out from London. In that year and in 1611 he produced famous drawings of the Moon's surface, which he bequeathed to the Northumberland

¹¹ Some scholars say Lipperehey as an alternative spelling.

¹² Some scholars say 5 August 1609, reflecting the 11 day Gregorian Calendar issue

family and which were subsequently donated to the British Museum. One of them is pictured below.



A few months later Galileo improved the magnification (to x 30 or more) of the model which Lippershey (pictured p.28) had begun. This enabled his famous observations of the moons of Jupiter.

We have been unable to link any of the individuals named in this section to Battle or even to East Sussex.



In conclusion, Edmund Langdon's personal life remains something of a mystery, with several interpretations possible: scholar turns to conman to survive hard times; or two different people; or maybe even identity theft. Langdon's work, when viewed in context, sheds light on scientific development in the early 17th century, as thinking emerged from astrology and ancient beliefs into an era of observation and inference. Langdon seems to have been on the cusp of these changes, if not himself an innovator.

**Adrian and Sarah Hall
and the Battle and District Historical Society (BDHS)
Research Group**

1 October 2017

BIBLIOGRAPHY

The sources for this booklet were:

Arroyo, S. Astrology, Psychology, and The Four Elements: An Energy Approach to Astrology and Its Use in the Counseling Arts CCRS Publications, 1975

Berry, A. The first telescope? Daily Telegraph 1991

Boylan, P. Thoth, the Hermes of Egypt: a study of some aspects of theological thought in ancient Egypt. London: Milford, 1922

Wallis Budge, EA. The Gods of the Egyptians or Studies in Egyptian Mythology London: Methuen & Co, 1904

Chapman, Dr A. A new perceived reality: Thomas Harriot's Moon maps. News and Reviews in Astronomy and Geophysics 2009; 50: 1.27-1.33.

Cook, Judith Dr Simon Forman: A Most Notorious Physician. Chatto and Windus, 2001

Cunnington, B.H. Wiltshire Quarter Sessions Records: Seventeenth Century

Bonaventure, St. De Dieta Salutis. Reink Books, 2017 (reprinted from 1497 edition)

Dygges, Leonard. A Geometrical Practise Named Pantometria, ed. and completed by Thomas Dygges, 1571

Forman, S. The Astrologically Judgements of Physick and other Questions 1606. The Casebooks Project. A digital edition of Simon Forman's and Richard Napier's medical records 1596-1634. <http://www.magicandmedicine.hps.cam.ac.uk/view/text/normalised/TEXT5>

Johnson Francis R. Astronomical Thought in Elizabethan England. A Study of the English Scientific Writings from 1500 to 1645. Huntingdon Library Publications, 1937

King, HC. The History of the Telescope, Cambridge, MA: Sky Publishing, 1955

Langdon, E. Speculum Planetarum 1610. Ashmolean Manuscripts, Bodleian Library, Oxford University Press.

Moulton, Thomas. Myrroure or Glasse of Helth 1577

O'Connor J.J and Robertson E.F. Thomas Digges. MacTutor Biography, 2002 and Biography of Thomas Digges, School of Mathematics and Statistics, University of St Andrew's, Scotland.

Oxford Dictionary of National Biography, OUP, Oxford, 2004.

Raach, John H A Directory of English Country Physicians, 1603-1643. London: Dawsons of Pall Mall, 1962.

Ronan, C.A. The origins of the reflecting telescope. Journal of the British Astronomical Association 1991; 101(6); 335-342.

Ronan CA and Satterthwaite G: The Digges Telescope. Did the Reflecting Telescope Have English Origins? <http://www.chocky.demon.co.uk/oas/diggeshistory.html> (2002)

Stöffler, Johannes. Almanach Nova 1506

Sullivan GA, Stewart A, Lemon R, et al. The Encyclopaedia of English Renaissance Literature. Oxford: Wiley Blackwell, 2012.

The Galileo Project. <http://galileo.rice.edu>

Thomas, K. Religion and the Decline of Magic: Studies in Popular Beliefs in Sixteenth and Seventeenth-Century England. London: Weidenfeld and Nicolson, 1971

Traister, B.H. The Notorious Astrological Physician of London: works and days of Simon Forman. Chicago, London: The University of Chicago Press, 2001

CREDITS FOR ILLUSTRATIONS

Unless otherwise credited, illustrations are open source

Page 1	Sussex Archaeological Society
Page 2	Bodleian Libraries' Ashmole Collection, University of Oxford
Page 4	By kind permission of the Master and Fellows of Corpus Christi College, Cambridge
Page 5	By kind permission of the Master and Fellows of Corpus Christi College, Cambridge
Page 9	Copyright Ashmole Museum, University of Oxford
Page 11	MS.Ashm.433 Front cover: by permission of the Bodleian Libraries, University of Oxford
Page 13	Siena Cathedral: open source
Page 14	MS.Ashm.433 Title page: by permission of the Bodleian Libraries, University of Oxford
Page 15	MS.Ashm.433 fol 2r: by permission of the Bodleian Libraries, University of Oxford
Page 17	MS.Ashm.433 fol 136r by permission of the Bodleian Libraries, University of Oxford
Page 20	Copyright: Wellcome Library
Page 22	MS.Ashm.433 fol 151: by permission of the Bodleian Libraries, University of Oxford
Page 22	Keith Foord and Gina/Kevin Doherty, Battle and District Historical Society Research Group

- Page 23 Wikimedia Commons
- Page 25 British Astronomical Association/Dr Allan Chapman “Thomas Harriot- the first telescopic astronomer”, 2008
- Page 26 Wikimedia Commons: A Perfitt Description of the Caelestiall Orbes 1576
- Page 27 WSRO Petworth House Archives HMC 241/9 f 30. Image provided by West Sussex Record Office and permission to publish given by Lord Egremont
- Page 28 Wikipedia Commons